

## The AGRU Story

### From the foundation till today

Alois Gruber senior founded a **locksmiths** in Bad Hall and an **anodizing** company in Grünburg in 1948. The locksmith company was closed in the 1950s, the focus being placed on the anodizing business, which was extended by a **powder coating** and **wet paint shop**. These competencies are now merged today in Grünburg, Upper Austria as part of **AGRU** Oberflächentechnik GmbH.

Alois Gruber senior laid the cornerstone for our current market success in 1961 with the decision to commence plastic pipe production. This area has continually been built up over the years. Initially with the production of **polypropylene** and **polyethylene**, later also by the manufacture of sheets, round bars and welding rods. The first injection molds for the production of **fittings** for the pipe industry were commissioned in 1966.

In the following years, AGRU expanded the headquarters in Austria and opened new production sites abroad. In 1998, **Mag. Alois Gruber** took over the business of his father. Since then we at **AGRU** have been concentrating on expanding and optimising plastic production.

## Company Background

### AGRU - The Plastics Experts

High-quality products made from engineering plastics.

As a reliable, professional supplier, AGRU offers everything from semi-finished products through to technologically optimised injection moulded fittings, all from a single source. Founded back in 1948 by Alois Gruber senior in Austria, nowadays the company is one of the world most important single-source suppliers for high-quality piping systems, semi-finished products, concrete protection liners and lining systems made from engineering plastics. With its expertise in producing engineering plastics components and developing tailored solutions, AGRU is present in virtually every sector of industry. Application areas include water and gas infrastructure, the energy sector, chemical and heavy industries, semiconductor and life-sciences (PURAD), tank and apparatus building, naval and aviation industries, civil engineering and mining, building construction.

### AGRU Mission

AGRU supplies the plastics technology that makes customers from all over the world successful in their widely differing industries. AGRU implements custom solutions and application-oriented new developments with the highest flexibility – with precision and economically.



# AGRU Global Locations

## Headquarter - AGRU In Bad Hall, Austria



## AGRU In Bad Hall, Austria (Factory Top View)



## AGRU Ability & Global Operations

Besides the main plant in Bad Hall, AGRU operates production plants in the USA, Germany, Poland and China.

The tight global sales network enables the supply of more than 150 countries with AGRU products.

### AGRU Production Capacity



AGRU  
production

100.000 TONNES/YEAR



115.000 M<sup>2</sup> FLOOR SPACE



PLANTS IN 5 COUNTRIES



## AGRU China

### AGRU In Taicang China

In 2005, AGRU China was founded in Taicang near Shanghai to supply Chinese market efficiently. Production and sales took place locally. Export was made for Asian areas including Hong Kong and Macau.



### AGRU In Jiangsu China

Due to rapid rise in local and regional sales, AGRU was invested in Jiangsu for new plant facility in 2023. AGRU Pipe Technology (Jiangsu) Co., Ltd. is a formal subsidiary of AGRU Austria. It is a wholly foreign-owned enterprise and a 100% subsidiary of AGRU.

AGRU products are mainly used in the following applications: gas and water supply, mining, chemical industry, semiconductor industry, pharmaceutical industry, plant irrigation, construction engineering, gas pressure pipelines and environmental engineering.

The purpose of AGRU Pipe Technology (Jiangsu) Co., Ltd. is to provide and expand services in mainland China. AGRU provides customers high-quality products and is proudly regarded as a long-term, competitive and reliable partner for customers in mainland China & overseas markets.

## AGRU Changsu City, Jiangsu (Office & Factory)



## AGRU Changsu City, Jiangsu (Factory Top View)



## Flame Retardant Polypropylene (PPs) Systems

**Flame Retardant polypropylene (PPs)** is a PP homopolymer, which is modified with a flame retardant additives.

PPs can be classified as a material with higher flame resistance. Flame retardant and electrically conductive (PPs-el ESD) polypropylene is made of PP copolymer and is equipped with both flame-resistant and electrically conductive / anti-static properties. AGRU products made of polypropylene grey, natural and white (made of PPH) complete our extensive range of PP products.

**AGRU products passed tests of BS476 Pt 7, DIN 4102, and UL94, fully meeting DW/154 requirements.**

It is well suited for intake and exhaust ventilation systems, fume cupboards, degassing pipes, and flue lining systems.

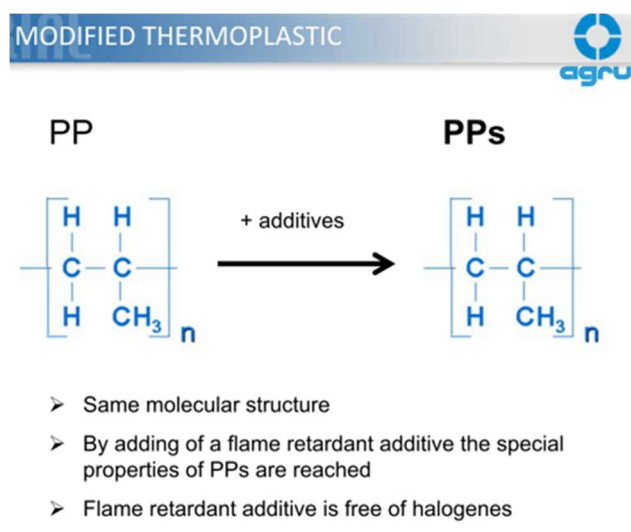

### Features of PPs (Polypropylene-self extinguishing)

- Flame retardant
- Safety and sustainability for different applications, where
  - Explosive media is transported
  - Easy flammable gas is transported
  - High chemical resistance is needed
- Excellent alternative for high grade metal alloys
- Best choice for hospital, university and laboratory.





## Product, Quality and Standards

Committed to top-notch quality, caring for the environment & workers safe, AGRU Jiangsu has been on EN ISO 9001 certified since 1995.

### Standards

- Material: PPs
- Ductwork constructed: DW/154
- Flammability (Fire Retardant) Classification: BS476 Part 7, DIN4102 and UL94
- Mill's test standard: EN10204
- Colour: Grey
- Outdoor UV Resistance: Suggest to apply additional protection by AGRU UV Paint

#### Supply programme:

Available up to MOP 10 bar

- Pipes OD 20 mm - 1200 mm
- Fittings, injection moulded  
OD 20 mm - 500 mm
- Fittings, segmented  
up to OD 1200 mm
- Accessories (flanges)  
OD 32 mm - 160 mm
- Welding machines &  
Assembly tools



#### Modified material grades - the perfect solution for special demands

In order to comply with the numerous specific requirements for chemical piping and apparatus engineering the flame retardant and electro conductive materials PP-s, PP-s-el and HDPE-el are offered.

During the operation of thermoplastic piping systems e.g. electrostatic charging can be caused by transport of media and gases. Piping systems made of antistatic plastic materials provide a durable and safe solution in such applications. AGRU piping systems and semi-finished products made of electro conductive plastic comply with the ATEX guidelines and can be applied in explosion protected (EX) areas. Flame retardant piping products are offered and used especially for applications in exhaust and ventilation areas.



## AGRU PPs Ventilation Pipes



## AGRU PPs Ventilation Pipe

Agru China PPs Ventilation Pipe

Specification	OD/mm	Thickness/mm (S)		Product Length/(mm) (H)
63	63	3.6		5000
75	75	1.9		5000
90	90	2.2		5000
110	110	2.7		5000
125	125	3.1		5000
140	140	3		5000
160	160	3		5000
180	180	3		5000
200	200	3		5000
225	225	3.5		5000
250	250	3.5		5000
280	280	4		5000
315	315	5		5000



Agru China PPs Ventilation Pipe

Specification	OD/mm	Thickness/mm (S)	L/mm	Product Length/(mm) (H)
355	355	3.5	/	3000
400	400	3.5	/	3000
450	450	4	/	3000
500	500	5	80	3000
560	560	5	90	3000
630	630	6	120	3000
710	710	6	130	3000
800	800	8	130	3000
900	900	8	140	3000
1000	1000	10	160	3000
1200	1200	12	180	3000

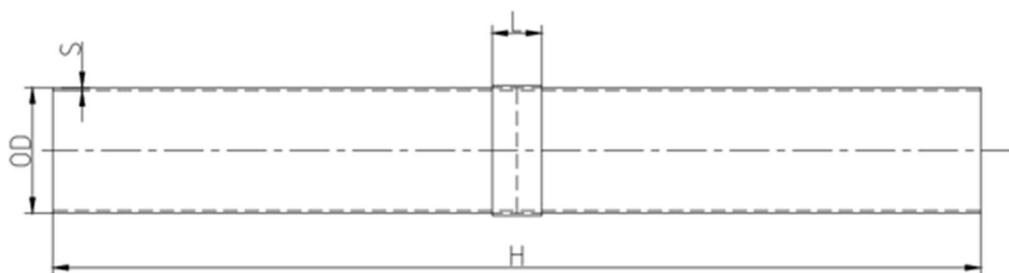

All dimension in mm

# AGRU PPs Ventilation Fittings

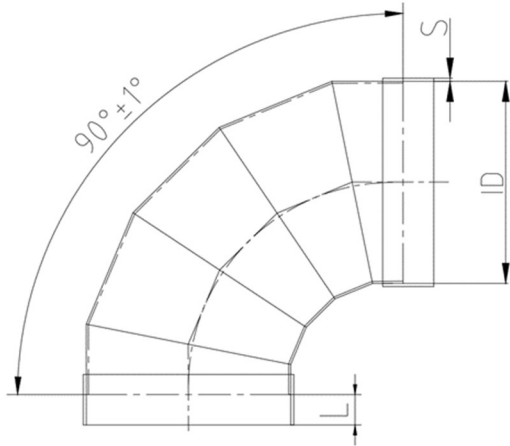

AGRU 90D ELBOW

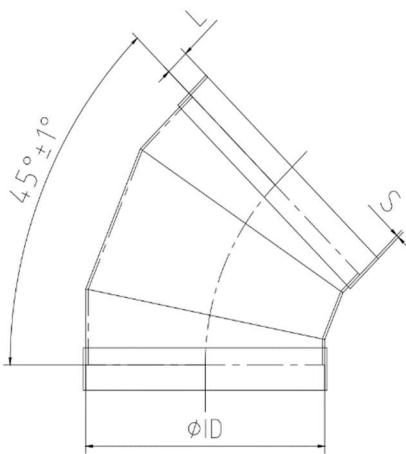

AGRU 45D ELBOW

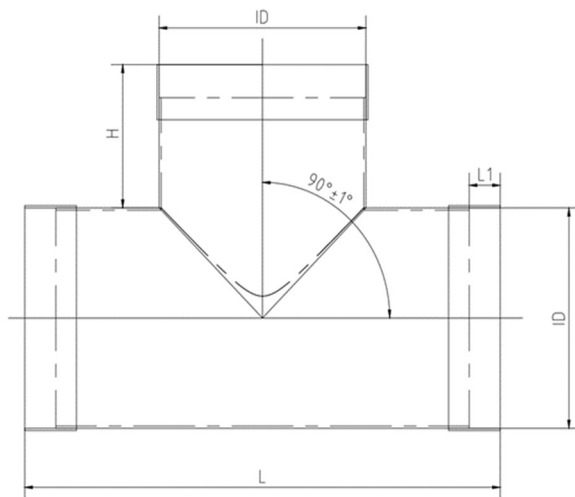

AGRU TEE



## AGRU PPs Ventilation Fittings

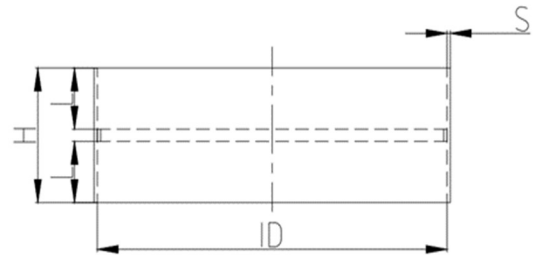
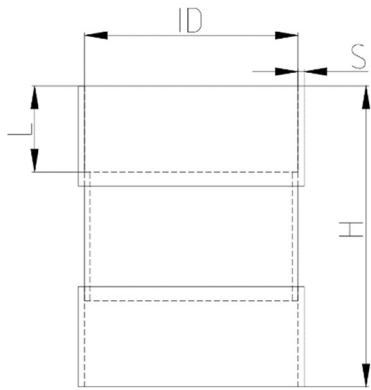

AGRU DOUBLE SOCKET

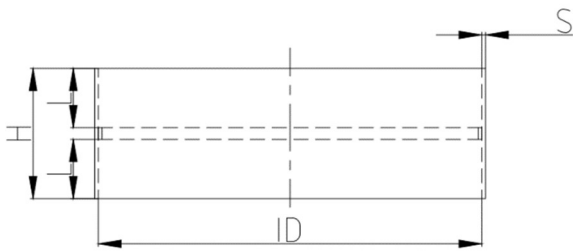

AGRU END CAP

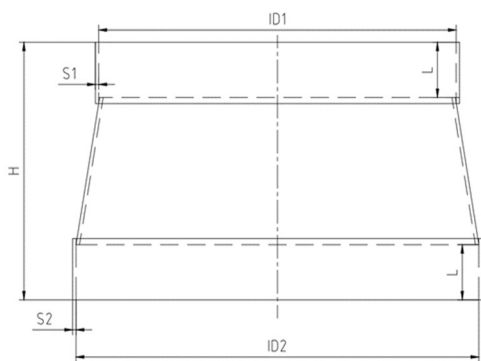

AGRU REDUCER

## AGRU PPs Ventilation Fittings

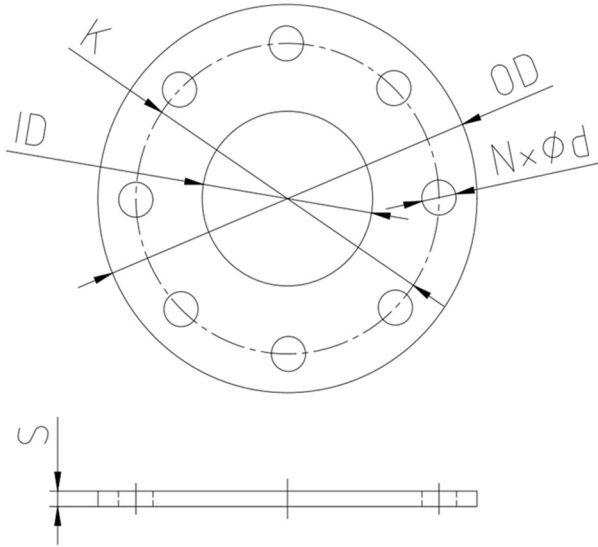

AGRU FLANGE

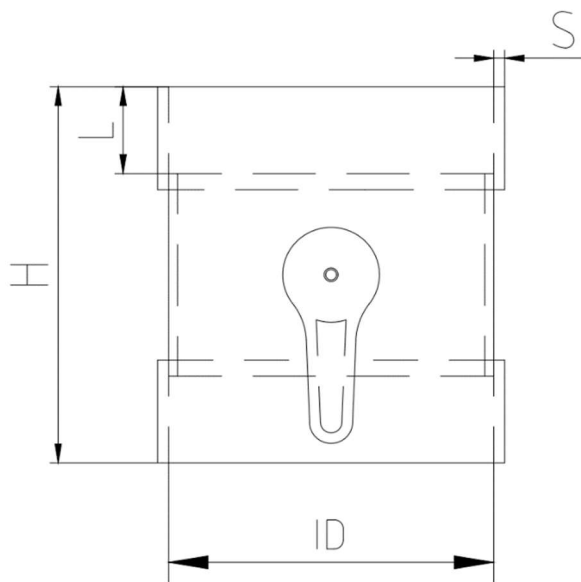

AGRU DAMPER

## AGRU Welding Fillers

**Welding-Rod**  
circular profile  
extruded

**Hot-gas-welding**  
PPs grey

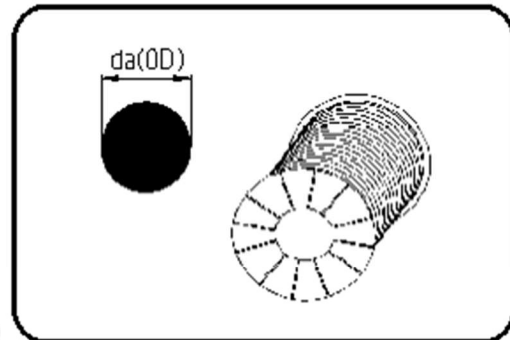

Code 410

Dimension	Code	Detail	da(OD) mm	Weight/ Gewicht
3	17.410.0000.30	3mm	3	1,00
4	17.410.0000.40	4mm	4	1,00

### Technical data for PPs grey welding rod material

Material	Welding force(N)		Hot air temperature (°c)	Air quantity (l/min)
	Rod Ø3mm	Rod Ø4mm		
PPS,PPS-el	15-20	25-35	300-340	45-55

- Supply from Austria



**Technical data for semi-finished products in PPs**  
**GUIDE VALUES FOR THE RAW MATERIAL FOR THE WELDING ROD**

	Property	Standard	Unit	PP-H s grey
	Specific density at 23°C	ISO 1183	g/cm <sup>3</sup>	0,93
	Melt flow rate MFR 190°C/5 kg	ISO 1133	g/10min	0,80
Mechanical Properties	Tensile stress at yield	ISO 527	MPa	30
	Elongation at yield	ISO 527	%	>6
	Elongation at break	ISO 527	%	>50
	Impact strength unnotched at +23°C	ISO 179	kJ/m <sup>2</sup>	no break
	Impact strength unnotched at -30°C			28
	Impact strength notched at +23°C	ISO 179	kJ/m <sup>2</sup>	9
	Impact strength notched at 0°C			2,8
	Impact strength notched at -30°C			2,2
	Ball indentation hardness acc. Rockwell	ISO 2039-1	MPa	72
	Flexural strength (3,5% flexural stress)	ISO 178	MPa	37
Modulus of elasticity	ISO 527	MPa	1300	
Thermal Properties	Vicat-Softening point VST/B/50	ISO 306	°C	85
	Heat deflection temperature HDT/B	ISO 75	°C	85
	Linear coefficient of thermal expansion	DIN 11359-2	K <sup>-1</sup> x 10 <sup>-4</sup>	1,6
	Thermal conductivity at 20 °C	DIN EN 12667	W/(mK)	0,2
	Flammability	UL94	--	V-0
Electrical Properties	Specific volume resistance	DIN EN 62631-3-1	OHM cm	>10 <sup>15</sup>
	Specific surface resistance	DIN EN 62631-3-2	OHM	>10 <sup>15</sup>
	relative dielectric constant at 1 MHz	DIN 53483	--	
	Dielectric strength	DIN IEC 60243	kV/mm	30-45
	EU 10/2011 approved	EU 10/2011	--	No
	FDA	--	--	No
	UV stabilized	--	--	No
	Colour	--	--	Grey (similar RAL 7037)

Recommended temperature range: -5°C - +95°C

## AGRU UV Coating

Brand:	AGRU
Country of Origin:	Austria
Model Name:	AGRU HXCOATING UV PAINT
Product description:	UV Protection Coating for Outdoor PP Duct
UV Protection:	The painting reflects and absorbs UV radiation / sunlight, thus reducing thermal stresses and increasing the pipeline lifetime.

### DESCRIPTION

AGRUCOATING is a liquid synthetic resin paint for indoor and outdoor applications for plastic surfaces.

### PHYSICAL PROPERTIES

Specific Gravity	1.41 g / cm <sup>3</sup>
Flash point	43 ° C (109.4 °F)
Boiling point:	140 ° C (284 °F)
Ignition temperature	225 ° C (437 °F)
Drying time, until painting can be touched	1 hour
Drying time	6 hours
Colour	Light gray (approximate RAL 7035)
Maximum time of storage	3-5 years (temperature > 10°C)



### INFORMATION ON THE HANDLING OF THE PRODUCT

#### AGRU article numbers:

HXCOATING03: 1 kg Coating (=0,71 l) Weight including the metal color pot: 1,1 kg  
 HXCOATING04: 4 kg Coating (=2,83 l) Weight including the metal color pot: 4,3 kg

For the safe handling of the product AGRU asks and recommends to consider and observe the information of the Material Safety Data Sheet (MSDS).

### APPLICATION TEMPERATURE

at least 10 ° C (50 °F)

### CONSUMPTION

about 0.1 l / 0.8-1m<sup>2</sup>  
 about 1 l / 8-10 m<sup>2</sup>

HXCOATING03: is enough for approximate 5.68 - 7.1 m<sup>2</sup> of painted area  
 HXCOATING04: is enough for approximate 22.64 - 28.5 m<sup>2</sup> of painted area

### UNDERGROUND AND PREPARATION

The substrate (surface to be coated) must be clean, dry, dust -free and free of grease.  
 Sand and clean well bonded old paintwork thoroughly.  
 Poorly adhering existing coatings have to be completely removed.  
 Clean contaminated surfaces thoroughly mechanically.

Peeling (roughening) of the surface with sandpaper 120 is strictly recommended.

# AGRU UV Coating Processing Guidelines

## PROCESSING GUIDELINES

BEFORE USE STIR THE COATING AS GOOD AS POSSIBLE!

The temperature of the paint object must be between + 10 ° C and + 25 ° C. Do not process with extremely high humidity (higher than 80%-danger of drying delay, or loss of adhesion). Processing is carried out by brushing, rolling or spraying, depending on the purpose there are one or two painting steps recommended. Respect the drying time between two coating processes. For processing (painting) standard ÖNORM B 2230 is basically valid.

AGRUCOATING can be applied with a brush, roller or sprayer. The paint can be done by using a soft brush, nap roller or spray system. AGRUCOATING has always to be applied to clean and dry surfaces.

## DRYING

At a temperature of about 20 ° C and 55% (relative air humidity) the paint is dry after 60 minutes and tack-free after 4 hours. AGRUCOATING can be painted over after approximately 6 hours with conventional synthetic enamel. Weathering can affect drying. The optimum final bonding to the surface is achieved after a few days!

## CURE (DRY TIME)

It is necessary to ensure sufficient drying time, the paint has to be protected from bad weather conditions (rain, snow, hail, ..) . High air humidity and low temperatures increase drying time. The paint should not be applied at temperatures <10 ° C (50°F).

## CLEANING EQUIPMENT

Tools and equipment used for the painting can be cleaned with a mild solvent such as mineral spirits or paint thinner.

## UV RADIATION

The painting reflects and absorbs UV radiation / sunlight, thus reducing thermal stresses, furthermore increasing the lifetime.

## OTHER IMPORTANT FACTS

DO NOT USE THE COATING IF RAIN OR FROST ARE FORECASTED WITHIN 24 HOURS RAIN / FROST IS FORECAST!

The tank must be tightened after use.

AGRUCOATING cannot be diluted with water.

One painting is usually sufficient, in the case of a second painting, the curing time must be observed approximately 6 hours.

## STORAGE

Frostproof storage is necessary!



# Transport, Handling and Storage Guidelines

## Transport and handling

At the transport and handling of pipes and fittings, the following guidelines have to be observed in order to avoid damages:

Pipes out of PP-H, special materials (PP-R-s-el, PP-H-s, PE-el) and prefabricated components (for example segmented bends) may only be loaded resp. transported with special care at pipe wall temperatures below 0°C.

Impact- and bending stresses at temperatures < 0°C have to be avoided.

Damages of the surface (scratches, marks, ...), as they occur at dragging of pipes, have to be avoided.

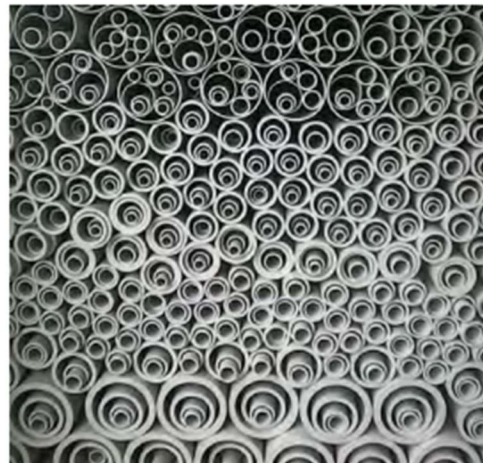

## Storage

At the storage of pipes and fittings, the below stated regulations have to be observed in order to avoid a quality decrease:

The storage area has to be even and free from waste, such as stones, screws, nails, etc.

At piling of pipes, storage heights of 1 m may not be exceeded. In order to avoid a rolling away of the pipes, wooden wedges have to be situated at the outside pipes. At pipes > OD 630mm, maximum two rows may be stored on top of one another. Pipes > OD 1000mm have to be stored loosely.

Pipes have to be stored flat and without bending stress, if possible in a wooden frame.

Natural and grey coloured products have to be protected against UV radiation at a storage outdoors. According to the standard EN 12207-2 pigmented (orange, blue) pipes can be stored outside for a period of 12 months.

Pipes and fittings out of PP-R-s-el and PE-el have to be protected at storage against humidity and UV radiation (no outdoor exposure, use of dry warehouses).

### Attention!

As the special types PP-R-s-el and PE-el suffer the danger of absorption of humidity at a storage period above 12 months, it is recommended to check the usability of the material by means of a welding test.



## Hong Kong & Macau - Prestigious Job References

### Hospitals and Medical Centres:

- Hong Kong Children's Hospital
- New Acute Hospital, Kai Tak
- United Christian Hospital - Expansion
- Union Hospital – New Extension Works
- Gleneagle Hospital
- St Paul Hospital – Expansion
- Prince of Wales Hospital (Sha Tin)
- Caritas Medical Centre Phase 2



Hong Kong Children Hospital



New Acute Hospital





Union Hospital



Gleneagle Hospital



Caritas Medical Centre Ph 2

## Universities & Schools:

- City University of HK - Jockey Clubs One Health Tower
- City University of HK – Fong Yun Wah Building
- HKU - Academic Building
- HKU – the Faculty of Medicine Building
- HKU – New Stem Cell Laboratory
- HK Academy at Sai Kung
- Baptist University – School of Chinese Medicine
- Baptist University – Cha Shi Ming Science Tower
- VTC Chai Wan Higher Education
- The Education University of HK
- HK South Island School



The Education University of Hong Kong





**Baptist University – School of Chinese Medicine**



**HKU – Medicine Building**

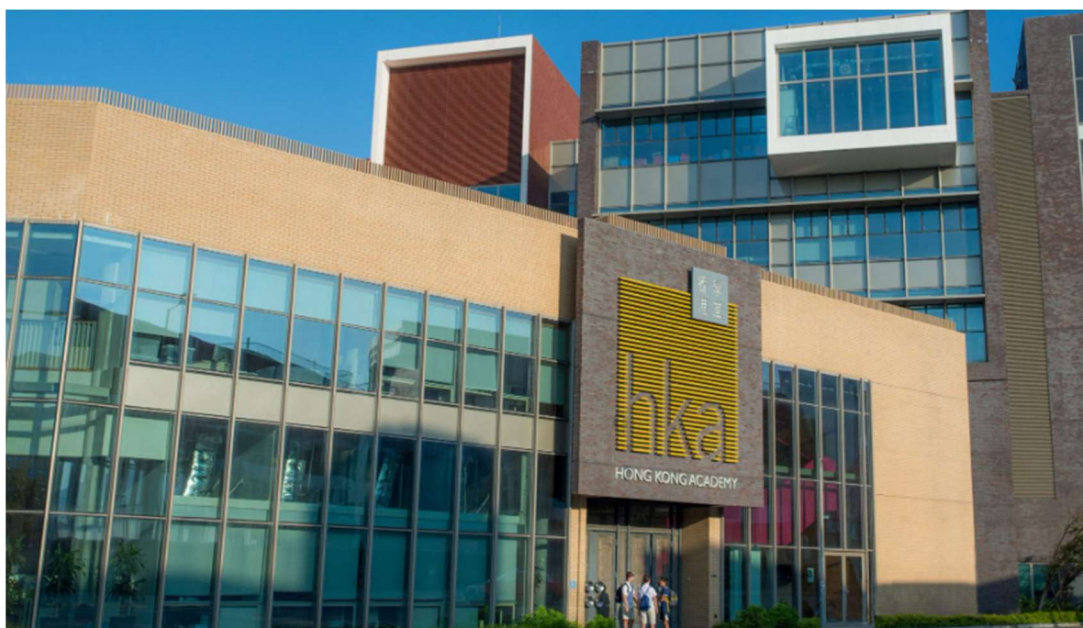

**HK Academy at Sai Kung**

## Commercial & Others:

- HK Science Park Ph 2
- HK Science Park Ph 3 Blok 16W
- HK Science Park SME Lab WC103
- HK Science Park Conversion to Full Wet Laboratory at 6W
- HK Science Park Expansion Stage 1
- HK Science Park 20E
- HK Science Park Ph 2 B15W
- HK Science Park 17W
- HK Science Park SPX2
- HK Red Cross headquarters
- HK Disneyland – UFO Cool Zone
- HK Disneyland – Tomorrowland Autopia



Science Park Expansion



HK Disneyland Tomorrowland



## Application - Oversea



AGRUCHEM PP PIPES  
AND FITTINGS FOR  
NATURAL FILTER PLANT



PP-H SHEETS, PIPES AND  
PP-R FITTINGS FOR RINSE TANK

## Manufacturer:

### AGRU Pipe Technology (Jiangsu) Co., Ltd.

No. 6, Lecheng Road, Bixi Street, Changhsu City, Jiangsu Province

T: +86-0512-80600-294

F: +86-0512-82011-180

Email: sales@agru.cn

### AGRU Kunststofftechnik GmbH

A – 4540 Bad Hall Austria

T: +43 (0) 7258 7900

F: +43 (0) 7258 3863

Email: office@agru.at

Website: www.agru.at

## Exclusive Distributor (Hong Kong and Macau):



### OFFICE:

5/F Henan Building, 90 Jaffe Road, Wanchai, Hong Kong

香港灣仔謝菲道 90 號 豫港大廈 5 樓

T: +852 2528 0999 F: +852 2528 3113 Email: [info@kembla.com.hk](mailto:info@kembla.com.hk)

Website: www.kembla.com.hk

### RETAIL SHOP:

G/F 413 Shanghai Street Yau Ma Tei, Kowloon

九龍油麻地上海街 413 號地下 (油麻地地鐵站 A1 出口)

T: +852 3428 2521 F: +852 3428 2575 Email: [shop@kembla.com.hk](mailto:shop@kembla.com.hk)

G/F 22A Swatow Street, Wanchai, Hong Kong

香港灣仔汕頭街 22 號 A 地下 (灣仔地鐵站 B2 出口近利東街)

T: +852 2528 0388 F: +852 2528 0189 Email: [wanchai.shop@kembla.com.hk](mailto:wanchai.shop@kembla.com.hk)

### WAREHOUSE:

Lot 567-D Lau Shui Heung Rd Po Kat Tsai Village Fan Ling, New Territories

新界粉嶺流水響道布格仔村地段 D.D. 85 Lot Nos. 567-D

T: +852 2674 7880 F: +852 2674 7990