

Fig.1934 DN40-50

Pressure Independent Control Valve

FEATURES & BENEFITS

- Comprehensive flow range available, allowing for cost effective valve selections. The PICV Elite Prime has up to 25% higher max flow compared to the previous model
- Accurate over a wide ΔP range - up to 800kPa
- Class IV leakage
- PN16 rated product, suitable for high pressure applications
- Design validation testing to BSRIA BTS01. As per Cyclic Testing requirements, valve subjected to 10,000 cycles (equivalent to 15 years* of typical service)
- Comprehensive testing undertaken for each valve - pressure tested to BS EN 12266-1
- Integral test points for verification of ΔP and valve performance
- Built in convoluted integral diaphragm
- Smaller and lighter design suits applications with a small footprint

* based on two full stroke cycles per day



MATERIAL SPECIFICATION

Item	Description	Material
1	Body	Bronze BS EN 1982 (CC491K)
2	Bonnet	Bronze BS EN 1982 (CC491K)
3	End Cap	Bronze BS EN 1982 (CC491K)
4	P84 Test Point	DZR Brass BS EN 12165 (CW602N)
5	Setting Dial	Nylon 6
6	DP Controller	Stainless Steel 303
7	Springs	Stainless Steel 302
8	Diaphragm	EPDM
9	O-Rings	EPDM
10	O-Ring Insert	Stainless Steel 303S
11	Stem	Stainless Steel 303S

PRESSURE/ TEMPERATURE RATING

16 Bar / 0°C to 90°C

MEDIUM: Group 2 Liquids

END CONNECTIONS

BSP Female Taper to BS EN 10226-2



SPECIFICATION

The PICV shall have a constant control characteristic at all flow settings and control flow rates at differential pressures up to 800kPa. Flow rates will be externally adjustable, and set point recordable. Integral test points will be fitted to verify setting pressure allowing pumps to be set at optimum speed to maximise energy savings. Shall be manufactured from Bronze (CC491K), with Stainless Steel springs, and an EPDM diaphragm. Shall be rated to PN16 and operate at temperatures to 90°C. As Hattersley Elite Prime (Fig 1934).

SPARES:

Isolating cap part number 0ED13666H.

DIMENSIONAL DRAWINGS

DIMENSIONS & WEIGHTS

	A (mm)	B (mm)	C1 (mm)	C2 (mm)	D (mm)	E (mm)	END CONNECTIONS	WEIGHT (kg)
DN40	137.1	118	94	145	104	72	1 1/2" BSP Female Taper to BS EN 10226	3.60
DN50	161.5	118	99	150	106.5	78	2" BSP Female Taper to BS EN 10226	4.25

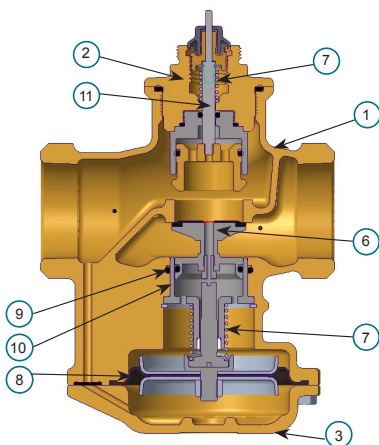

Actuator shown for reference only (supply separately)

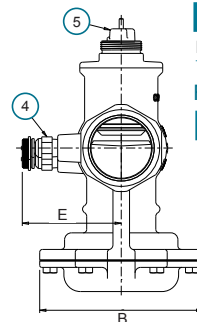
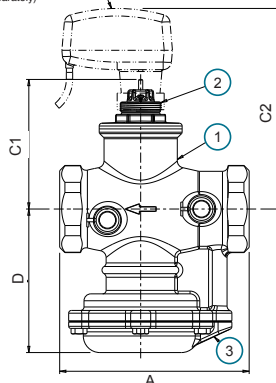

DIFFERENTIAL PRESSURE RANGE

	DN40	DN50
Flow (kPa)	50 - 800	40 - 800

FLOW RANGE

	DN40	DN50
Flow (l/s)	0.39 - 3.00	0.69 - 3.80

