

STOP VALVE (GLOVE VALVE) 15mm - 100mm(1/2inch - 4inch)



FEATURES

- The STOP VALVE is compact and economical.
- Used for efficient throttling of flow.
- Positive shut-off.
- Displas excellent flow regulating character-istics throughout the entire lift of the disc.

SPECIFICATIONS

Body material	Unplasticized Polyvinyl Chloride(PVC) Polypropylene(PP)
End Connectors	Socket End : 15mm(1/2inch) - 25mm(1inch) Threaded End : 15mm(1/2inch) - 50mm(2inch) Flanged End : 15mm(1/2inch) - 100mm(4inch)
Working Temperature	PVC:0°C - 50°C(30°F - 120°F) PP:-20°C - 80°C(-5°F - 175°F)
Max. Working Pressure	1.0MPa{10.2kgf/cm ² }[150PSI](at R.T).....15mm(1/2inch) - 50mm(2inch) 0.7MPa{7.1kgf/cm ² }[100PSI](at R.T).....65mm(2 1/2inch) - 100mm(4inch)

WORKING PRESSURE VS. TEMPERATURE

STOP VALVE

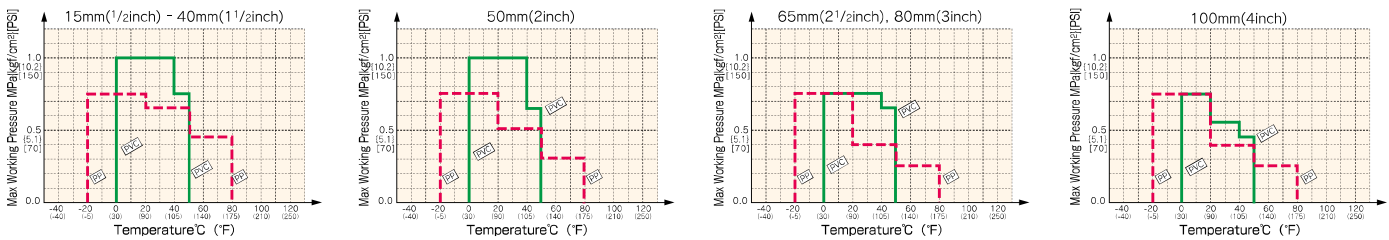

DIMENSIONS

- 15mm (1/2inch) - 30mm (1 1/4inch)
- 40mm (1 1/2inch) - 50mm (2inch)
- 65mm (2 1/2inch) - 100mm (4inch)

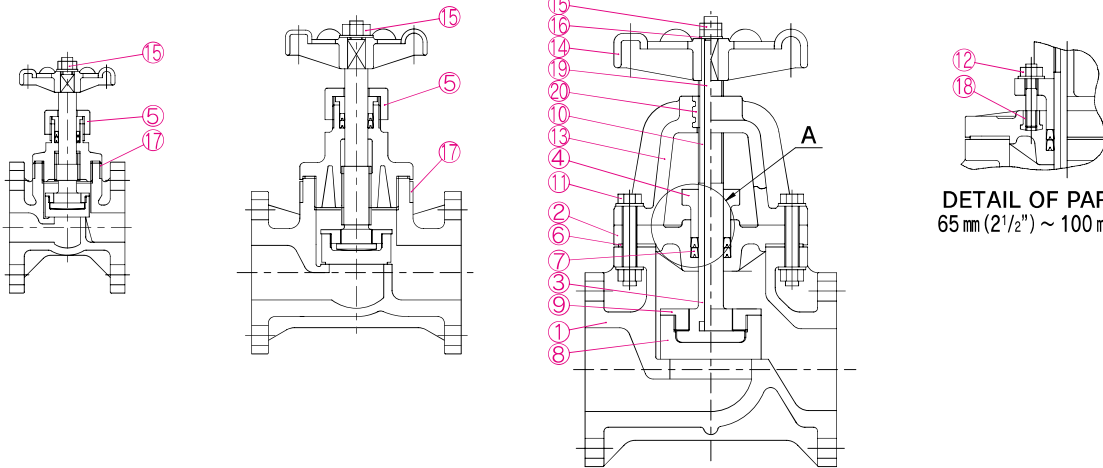

DETAIL OF PART A
65 mm (2 1/2") ~ 100 mm (4")

PARTS & MATERIALS

No.	DESCRIPTION	Pcs.	MATERIAL	No.	DESCRIPTION	Pcs.	MATERIAL
①	BODY	1	PVC, PP	⑪	BOLT·NUT	4	STAINLESS STEEL 304 65mm(2 1/2inch) and over
②	BONNET	1	PVC, PP	⑫	STUD BOLT·NUT	2	STAINLESS STEEL 304 65mm(2 1/2inch) and over
③	STEM	1	PVC, PP	⑬	SUPPORT OF STEM	1	PP 65mm(2 1/2inch) and over
④	GLAND	1	PVC, PP	⑭	HAND WHEEL	1	PP
⑤	GLAND NUT	1	PVC, PP Up to 50mm(2inch)	⑮	NUT(A)	1 2	PVC Up to 50mm(2inch) STAINLESS STEEL 304 65mm(2 1/2inch) and over
⑥	SHEET GASKET	1	EPDM, Others	⑯	WASHER	1	PVC Up to 50mm(2inch) STAINLESS STEEL 304 65mm(2 1/2inch) and over
⑦	GLAND PACKIKG	2	EPDM, Others	⑰	RING FOR REINFORCING*	1	STAINLESS STEEL PP Body 15mm(1/2inch)~50mm(2inch)
⑧	DISC	1	PP	⑱	INSERTED NUT	1	COPPER ALLOY(C3604) 65mm(2 1/2inch) and over
⑨	STEM HOLDER	1	PP	⑲	INSERTED METAL OF STEM	1	STEEL(SS400) 65mm(2 1/2inch) and over
⑩	STEM WTH TRAPEZOID SCREW	1	COPPER ALLOY(C3604) 65mm(2 1/2inch) and over	⑳	INSERTED METAL	1	BRONZE (BC6) 65mm(2 1/2inch) and over

*When the body is made of PP, it uses an Stainless Steel 304 reinforcing ring.

● FLANGED END

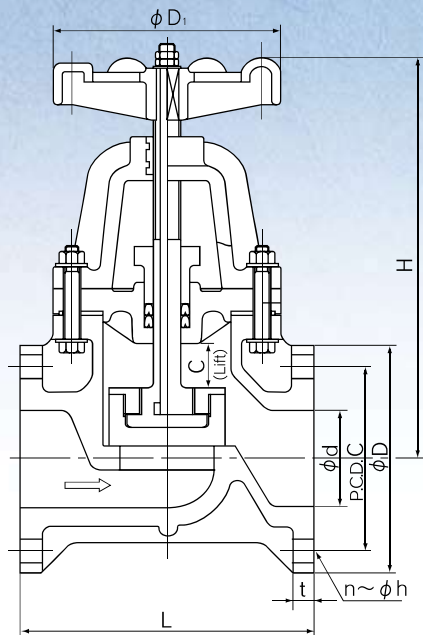

DIMENSIONS TABLE

JIS													Unit:mm	
Nominal Size	d	JIS 10K				L	t	Lift C	H		D ₁	Working Press. at R.T. MPa[kgf/cm ²][PSI]		
		D	C	n	h				Shut	Open		PVC	PP	
15	1/2	18	95	70	4	15	85	12	8	124	132	66	1.0{10.2}[150]	0.75{7.7}[110]
20	3/4	24	100	75	4	15	95	14	8	132	140	66	1.0{10.2}[150]	0.75{7.7}[110]
25	1	28	125	90	4	19	110	14	11	150	161	91	1.0{10.2}[150]	0.75{7.7}[110]
32	1 1/4	37	135	100	4	19	135	16	13	154	167	91	1.0{10.2}[150]	0.75{7.7}[110]
40	1 1/2	41	140	105	4	19	190	16	20	210	230	135	1.0{10.2}[150]	0.75{7.7}[110]
50	2	52	155	120	4	19	200	16	24	228	252	135	1.0{10.2}[150]	0.75{7.7}[110]
65	2 1/2	67	175	140	4	19	220	18	35	310	345	185	0.75{7.7}[110]	0.75{7.7}[110]
80	3	78	185	150	8	19	240	18	35	324	359	185	0.75{7.7}[110]	0.75{7.7}[110]
100	4	100	210	175	8	19	290	18	40	379	419	185	0.75{7.7}[110]	0.75{7.7}[110]

DIN													Unit:mm	
Nominal Size	d	DIN PN10				L	t	Lift C	H		D ₁	Working Press. at R.T. MPa[kgf/cm ²][PSI]		
		D	C	n	h				Shut	Open		PVC	PP	
15	1/2	18	95	65	4	14	85	12	8	124	132	66	1.0{10.2}[150]	0.75{7.7}[110]
20	3/4	24	105	75	4	14	95	14	8	132	140	66	1.0{10.2}[150]	0.75{7.7}[110]
25	1	28	115	85	4	14	110	14	11	150	161	91	1.0{10.2}[150]	0.75{7.7}[110]
32	1 1/4	37	140	100	4	18	135	16	13	154	167	91	1.0{10.2}[150]	—
40	1 1/2	41	150	110	4	18	190	16	20	210	230	135	1.0{10.2}[150]	0.75{7.7}[110]
50	2	52	165	125	4	18	200	16	24	228	252	135	1.0{10.2}[150]	0.75{7.7}[110]
65	2 1/2	67	185	145	4	18	220	18	35	310	345	185	0.75{7.7}[110]	0.75{7.7}[110]
80	3	78	200	160	8	18	240	18	35	324	359	185	0.75{7.7}[110]	0.75{7.7}[110]
100	4	100	220	180	8	18	290	18	40	379	419	185	0.75{7.7}[110]	0.75{7.7}[110]

ANSI													Unit:inch	
Nominal Size	d	ANSI CLASS 150				L	t	Lift C	H		D ₁	Working Press. at R.T. MPa[kgf/cm ²][PSI]		
		D	C	n	h				Shut	Open		PVC	PP	
1/2	15	0.71	3.50	2.38	4	0.63	3.35	0.47	0.32	4.88	5.20	2.60	1.0{10.2}[150]	0.75{7.7}[110]
3/4	20	0.94	3.86	2.76	4	0.63	3.74	0.55	0.32	5.20	5.51	2.60	1.0{10.2}[150]	0.75{7.7}[110]
1	25	1.10	4.25	3.13	4	0.63	4.33	0.55	0.43	5.91	6.34	3.58	1.0{10.2}[150]	0.75{7.7}[110]
1 1/4	32	1.46	4.61	3.50	4	0.63	5.31	0.63	0.51	6.06	6.57	3.58	1.0{10.2}[150]	—
1 1/2	40	1.61	5.00	3.88	4	0.63	7.48	0.63	0.79	8.27	9.06	5.31	1.0{10.2}[150]	0.75{7.7}[110]
2	50	2.05	5.98	4.74	4	0.75	7.87	0.63	0.95	8.98	9.92	5.31	1.0{10.2}[150]	0.75{7.7}[110]
2 1/2	65	2.64	7.01	5.49	4	0.75	8.66	0.71	1.38	12.20	13.58	7.28	0.75{7.7}[110]	0.75{7.7}[110]
3	80	3.07	7.52	6.00	4	0.75	9.45	0.71	1.38	12.75	14.13	7.28	0.75{7.7}[110]	0.75{7.7}[110]
4	100	3.94	9.02	7.50	8	0.75	11.42	0.71	1.57	14.92	16.50	7.28	0.75{7.7}[110]	0.75{7.7}[110]

● SOCKET END

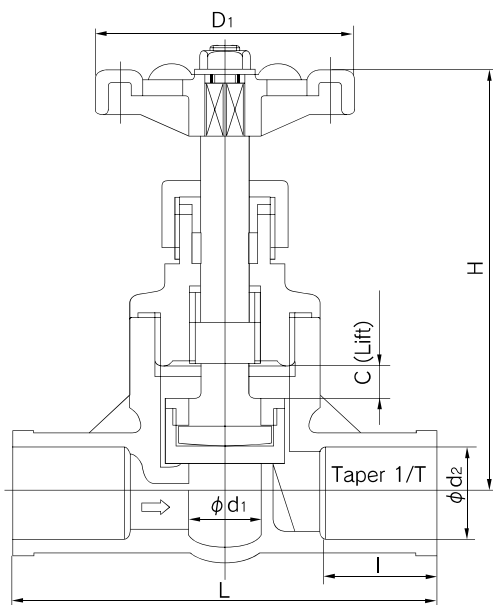

DIMENSIONS TABLE

JIS											Unit:mm	
Nominal Size	d ₂	d ₁	l	L	Taper 1/T	Lift C	H		Working Press. at R.T. MPa[kgf/cm ²][PSI]			
							Shut	Open	PVC	PP		
15	1/2	22.4 ± 0.2	15	30	110	1/34	8	124	132	1.0{10.2}[150]	0.75{7.7}[110]	
20	3/4	26.45 ± 0.2	18	35	130	1/34	8	132	140	1.0{10.2}[150]	0.75{7.7}[110]	
25	1	32.55 ± 0.25	25	40	150	1/34	11	150	161	1.0{10.2}[150]	0.75{7.7}[110]	

DIN											Unit:mm	
Nominal Size	d ₂	d ₁	l	L	Lift C	H		Working Press. at R.T. MPa[kgf/cm ²][PSI]				
						Shut	Open	PVC	PP			
15	1/2	20	15	16	82	8	124	132	1.0{10.2}[150]	0.75{7.7}[110]		
20	3/4	25	18	19	98	8	132	140	1.0{10.2}[150]	0.75{7.7}[110]		
25	1	32	25	22	114	11	150	161	1.0{10.2}[150]	0.75{7.7}[110]		

ANSI											Unit:inch	
Nominal Size	d ₂	d ₁	l	L	Taper 1/T	Lift C	H		Working Press. at R.T. MPa[kgf/cm ²][PSI]			
							Shut	Open	PVC	PP		
15	1/2	0.848	0.59	1.18	4.33	1/34	0.32	4.88	5.20	1.0{10.2}[150]	0.75{7.7}[110]	
20	3/4	1.058	0.71	1.38	5.12	1/34	0.32	5.20	5.51	1.0{10.2}[150]	0.75{7.7}[110]	
25	1	1.325	0.98	1.58	5.91	1/34	0.43	5.91	6.34	1.0{10.2}[150]	0.75{7.7}[110]	

●15mm (1/2inch) – 30mm (1 1/4inch)

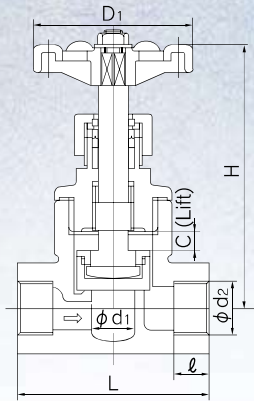

●40mm (1 1/2inch) – 50mm (2inch)

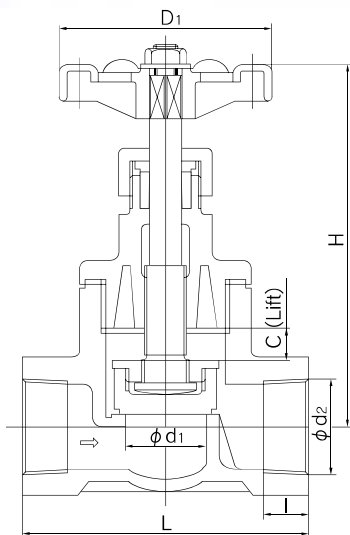

DIMENSIONS TABLE (Threaded End)

Nominal Size		d ₂	d ₁	ℓ	L	Lift C	H		D ₁	Working Press. at R.T. MPa[kgf/cm ²][PSI]	
mm	inch						Shut	Open		PVC	PP
15	1/2	Rc 1/2	15	15	85	8	124	132	66	1.0{10.2}{150}	0.75{7.7}{110}
20	3/4	Rc 3/4	18	18	95	8	132	140	66	1.0{10.2}{150}	0.75{7.7}{110}
25	1	Rc 1	25	20	110	11	150	161	91	1.0{10.2}{150}	0.75{7.7}{110}
32	1 1/4	Rc 1 1/4	35	25	135	13	154	167	91	1.0{10.2}{150}	—
40	1 1/2	Rc 1 1/2	41	25	140	17	218	235	135	1.0{10.2}{150}	—
50	2	Rc 2	52	27	180	22	237	259	135	1.0{10.2}{150}	—

Nominal Size		d ₂	d ₁	ℓ	L	Lift C	H		D ₁	Working Press. at R.T. MPa[kgf/cm ²][PSI]	
mm	inch						Shut	Open		PVC	PP
15	1/2	Rp 1/2	15	15	85	8	124	132	66	1.0{10.2}{150}	0.75{7.7}{110}
20	3/4	Rp 3/4	18	18	95	8	132	140	66	1.0{10.2}{150}	0.75{7.7}{110}
25	1	Rp 1	25	20	110	11	150	161	91	1.0{10.2}{150}	0.75{7.7}{110}
32	1 1/4	Rp 1 1/4	35	25	135	13	154	167	91	1.0{10.2}{150}	—
40	1 1/2	Rp 1 1/2	41	25	140	17	218	235	135	1.0{10.2}{150}	—
50	2	Rp 2	52	27	180	22	237	259	135	1.0{10.2}{150}	—

Nominal Size		d ₂	d ₁	ℓ	L	Lift C	H		D ₁	Working Press. at R.T. MPa[kgf/cm ²][PSI]	
inch	mm						Shut	Open		PVC	PP
1/2	15	NPT. 1/2	0.59	0.59	3.35	0.32	4.88	5.20	2.60	1.0{10.2}{150}	0.75{7.7}{110}
3/4	20	NPT. 3/4	0.71	0.71	3.74	0.43	5.20	5.51	2.60	1.0{10.2}{150}	0.75{7.7}{110}
1	25	NPT. 1	0.98	0.79	4.33	0.43	5.91	6.31	3.58	1.0{10.2}{150}	0.75{7.7}{110}
1 1/4	32	NPT. 1 1/4	1.38	0.98	5.32	0.51	6.06	6.58	3.58	1.0{10.2}{150}	—
1 1/2	40	NPT. 1 1/2	1.61	0.98	5.51	0.67	8.58	9.25	5.32	1.0{10.2}{150}	—
2	50	NPT. 2	2.05	1.06	7.09	0.87	9.33	10.20	5.32	1.0{10.2}{150}	—