

Fig. 77
Thermostatic Mixing Valve



FEATURES & BENEFITS

- Blends hot and cold water to ensure constant, controlled safe outlet temperature
- Fulfills the 'duty of care' requirements against scalding
- Ideal for healthcare, schools, workplace and domestic environments
- Flat face union ensures easy removal for maintenance
- Integral strainers and check valves
- Tamper proof adjustment
- WRAS Approved maximum operating temperature 85°C



MATERIAL SPECIFICATION

Component	Material	Specificationww
Body	Chrome Plated Brass	CW602N
Bonnet	Chrome Plated Brass	CW602N
Check Valve	Body - POM O-ring - EPDM Spring - Stainless Steel	- AISI304
Cap	ABS	-
Element	-	-
Water Flow Directors	PSU	-
Spring	Stainless Steel	AISI304
O-Ring	EPDM	-
Strainer	Stainless Steel	AISI304
Compression Olive	Brass	CW507L

LIMITS OF USE

Hattersley Fig. 77 valves have been approved for use on the following designated systems:

High Pressure (HP)	Low Pressure (HP)	Application	Max. Mixed Temperature
HP-B	LP-B	Bidet	38°C
HP-S	LP-S	Shower	41°C
HP-W	LP-W	Wash Basin	41°C
HP-T (TMV2)	-	Bath	44°C
HP-T44 (TMV3)	-	Bath	44°C

DIMENSIONAL DRAWING

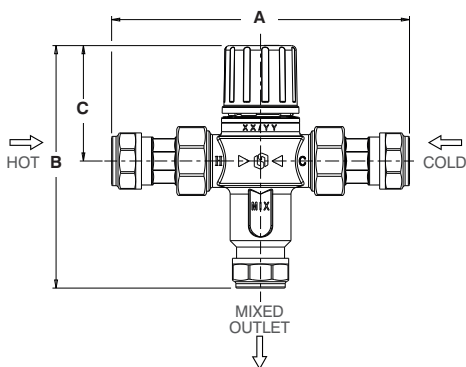

DIMENSIONS & WEIGHTS

Nom Size	mm	15	22
A	mm	131	155
B	mm	108	110
C	mm	51	51
Weight	kg	0.49	0.68

FACTORY SETTING

41°C

TEMPERATURE SETTING RANGE

30-50°C

MINIMUM HOT TO MIX TEMPERATURE

12°C

COLD WATER SUPPLY TEMPERATURE:

5-25°C

HOLD WATER SUPPLY TEMPERATURE:

55-65°C

TEMPERATURE STABILITY

±2°C

MAXIMUM WORKING PRESSURE

10 bar

SPECIFICATION

Pressure Rating: PN10.

Operator: Lockshield.

Supply Pressure Imbalance Dynamic: 2:1

Figure 77 Thermostatic Mixing Valve

is certified under the NSF TMV2

& TMV3 schemes and is a WRAS

approved product listed in the WRAS

Approvals Directory.