

Fig. 3873MG Fully Lugged Gearbox Operated Butterfly Double Regulating Valves

FEATURES & BENEFITS

- Valves are suitable for use with flanges conforming to BS EN 1092-2 PN16
- Valve to BS EN593
- Double Regulating Valves consist of a fully lugged, EPDM liner butterfly valve with a Double Regulating feature, which allows the valve to be used for isolation and to be reopened to its pre-set position to maintain required flow rate
- Ductile Iron Disc
- 420 Stainless Steel Shafts for superior strength



MATERIAL SPECIFICATION

Part	Material
Body	Ductile Iron (EN GJS-400-15)
Disc 3873MG	Ductile Iron (EN-G35-400-15) Epoxy coated
Liner	EPDM
Shaft	Stainless Steel 420 (ASTM A276 420)
Taper Pin	Stainless Steel 431 (ASTM A276 431)
O-Ring	Nitrile Rubber
Bushing	PTFE

DIMENSIONAL DRAWINGS

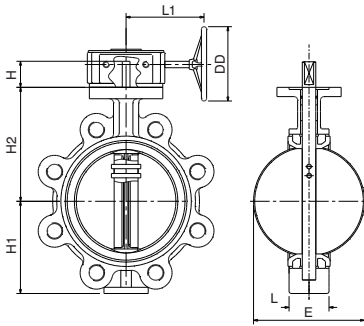

PRESSURE/ TEMPERATURE RATING

PN16
-10 to 120°C

TEST PRESSURES: (Hydrostatic)
SHELL: 24bar; Seat: 17.6 bar

SPECIFICATION

End connections compatible with
BS EN1092-2
PN16 flanges.

END CONNECTION:
Fully Lugged
OPERATOR:
Gearbox

DIMENSIONS & WEIGHTS

Size	mm	150	200	250	300	350	400	450	500	600
H2	mm	204	247	280	324	310	340	375	425	505
H1	mm	137	174	209	253	260	317.5	330	367	443
L	mm	56	60	68	78	78	102	114	127	154
H	mm	32	45	45	45	48	64	64	64	82
L1	mm	157	236	236	237	237	246	246	254	301
ØE	mm	155.6	202.5	250.5	301.6	333.6	389.5	440.5	489.7	592.7
DD	mm	145	300	300	300	300	300	380	285	400
Bareshaft Wgt	kg	10.0	17.4	25.0	34.0	52.0	81.0	106.0	140.0	220.0
Gearbox Wgt	kg	14.9	26.2	34.0	46.0	63.0	106.0	131.0	170.0	270.0
Kv		1825	2503	3876	6736	8135	12041	14121	18449	24125

Every effort has been made to ensure that the information contained in this publication is accurate at the time of publishing. Hattersley Ltd assumes no responsibility or liability for typographical errors or omissions or for any misinterpretation of the information within the publication and reserves the right to change without notice.