

Bronze Globe Valve

Fig. 300



- Cast Bronze Screwed Globe Valve
- Easy Operated Handwheel
- Precise Shutting Mechanism
- 1/2" up to 2"
- Rising Stem
- Rated Pressure PN 16

Material for ALL size (1/2" – 2"):

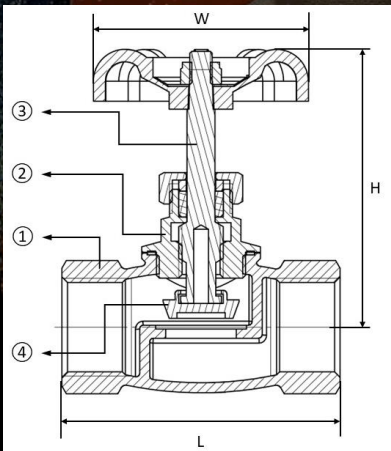

No.	Parts	Material	Spec.
1	Body	Cast Bronze	BS EN 1982:2008, CC499K
2	Bonnet	Cast Bronze	BS EN 1982:2008, CC499K
3	Stem	Copper Alloy (DZR)	BS EN 12165:2016 Table 7, CW602N
4	Seat	Copper Alloy (DZR)	BS EN 12165:2016 Table 7, CW602N

Dimensions:

Nominal Size	inch	1/2	3/4	1	1-1/4	1-1/2	2
	mm	15	20	25	32	40	50
L	Thread end to end	60	75	90	100	105	130
H	Height (close)	60	72	75	91	97	115
H	Height (open)	67	78	84	100	108	126
W	Handwheel Dia.	53	59	59	64	73	78

Specifications:

Working Pressure	16 Bar
Body Test Pressure	24 Bar
Seat Test Pressure	17.6 Bar
Thread connection	BS EN 10226-1:2004

Body Marking:



front side

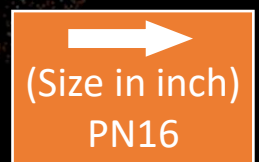

rear side