

Fig.MH739 / MHA739

Fixed Integral Orifice Double Regulating Valve (FODRV)

FEATURES & BENEFITS

- Single unit Y-Pattern globe valves incorporating an integral orifice plate to form a fixed orifice flow measurement unit with regulation and isolation capacity
- The Double Regulating feature allows the valve to be used for isolation and to be reopened to its pre-set position to maintain required flow rate
- Accuracy of flow measurement is $\pm 5\%$ at all open positions of the valve in accordance with BS 7350: 1990
- Primarily used in injection or other circuits requiring a double regulating valve for system balancing
- External spray epoxy coated for improved durability



MATERIAL SPECIFICATION

Part	Material
Body	Ductile Iron - BS EN 1563 GJS-450-10
Bonnet	Ductile Iron - BS EN 1563 GJS-450-10
Bonnet Gasket	Non-asbestos
Disc	EPDM Coated Cast Iron
Disc Bush	Bronze - BS EN 1982
Stern	Stainless Steel 410 - BS EN 10088-3 1.4006
Gland (65 to 150mm)	Brass - BS EN 12164 CW721R
Gland (200 to 300mm)	Cast Iron - BS EN 1561 EN-GJL-250
Packing	Non-asbestos
Seat Ring	Bronze - BS EN 1982

PRESSURE/ TEMPERATURE RATING

PN16 / -10 to 120°C
 Ratings align with BS EN 1092-2 PN16
 (formerly BS 4504)

SPECIFICATION

Y-Pattern globe valves suitable for flow regulation and isolation, supplied with Figure 631 test points to enable flow measurement. Valves conform to requirements of BS 7350 and ends are flanged to BS EN 1092-2 (formerly BS 4504).

END CONNECTIONS

MH739 Ends are flanged to BS EN 1092-2 PN16 (formerly BS 4504) and MHA739 Ends are flanged to ANSI B16.1 Class 125

DIMENSIONAL DRAWINGS

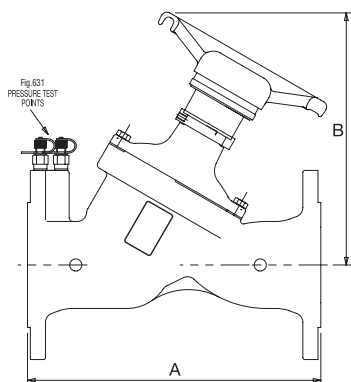

DIMENSIONS, WEIGHTS & COEFFICIENTS*

DN	Face To-Face A (mm)	Centre-To-Top B (mm)	Weight (kg)	Flow (Kv)	Headloss (K)	KVS
65	290	262	16.3	93	6.9	90
80	310	267	20.0	99	6.8	120
100	350	300	28.5	136	12.7	220
125	400	325	38.0	229	8.7	342
150	480	340	51.0	342	8.9	468
200	600	525	124.0	550	10.3	792
250	730	575	194.0	1052	6.0	1224
300	850	645	254.0	1367	7.8	1800

* Fully open position