

Ball Check Valve (W-HQ41X-16Q)

◆ Application:

The Watts W-HQ41X-16Q Ball Check Valve is designed to automatically open and close the spherical valve disc by the flow of medium itself, which is used to prevent the backflow of medium. It's generally used in petroleum, chemical industry, metallurgy, water treatment, etc.



◆ Features:

1. Simple Structure, light weight;
2. The Spherical disc closes quickly;
3. Good sealing performance;
4. Long service life, high Reliability.

◆ Operating Principles:

When the medium flows in accordance with the regulation direction, the spherical valve disc opens because of the force of medium; when the medium counters current, the spherical valve disc closes on its own quickly, relying on the flow of medium itself, to reach the purpose of preventing medium counter-current.

◆ Technical Specification:

Nominal Size:	DN50 ~ DN250
Working Pressure:	PN16
Working Temperature:	0°C ~ 80 °C
Fluid Medium:	For sewage and neutral water
Test Standard:	BS EN 12266-1

◆ Material:

Part	Body	Bonnet	Spherical Valve Disc	Ball
Material	Ductile Iron coated with Epoxy	Ductile Iron coated with Epoxy	Cast Iron coated with EPDM	NBR

◆ Installation Dimensions:

Connection Dimensions: BS EN 1092-2

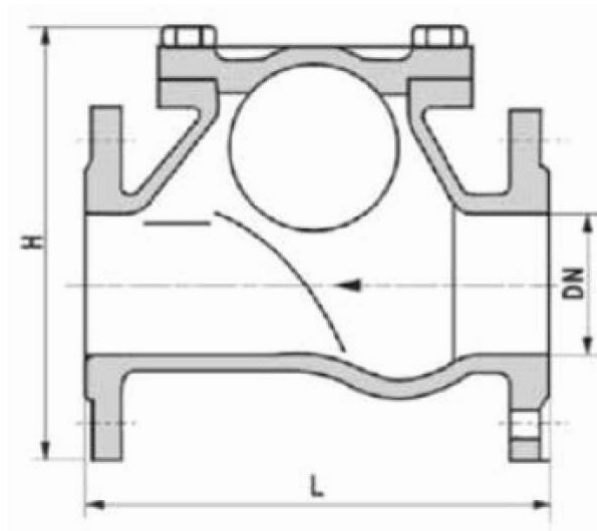

DN	50	65	80	100	125	150	200	250
L	180	200	260	300	350	400	500	600
H	185	210	245	280	335	400	495	600

◆ Typical Application:

1. Water plant and water source project;
2. Environmental protection;
3. Municipal facilities;
4. Electric power and utilities;
5. Construction industry;
6. Petroleum & Chemical industry;
7. Steel & Metallurgy
8. Papermaking industry.

◆ Installation Instructions:

- (1) The valve's rated parameters should match the equipment's. Make sure that the valve's rated flow satisfies the actual demand;
- (2) The installer must be trained or experienced so as to operate the installation correctly;
- (3) A thorough check after installation is needed to ensure no errors;
- (4) A thorough cleaning before installation is needed (chemical reagent can be applied if it is necessary) to ensure that there is not any rusting or dirt in the pipe. All the filters must be removed before washing to keep the pipe smoothly open;
- (5) When beginning to wash the system, it is suggested to install the valve on a temporary pipe. After finishing system cleaning, move the valve back and install it on the system's pipe;
- (6) Use flange and the corresponding bolts that meet the standard to connect the valve;
- (7) The direction of flow must accord with the direction of the arrow head on the valve body.